

Clinician Instruction Booklet

TAP® 3 ThermAcryl

TAP® 3 TL

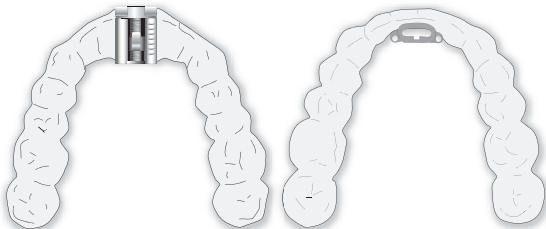

Table of Contents

Important Safeguards.....	3
Introduction.....	4
Warnings.....	7
Possible Side Effects.....	8
Fitting the TAP [®] 3 ThermAcryl [®] Trays.....	9
Reline Instructions	14
Fitting the TAP [®] 3 TL Trays.....	15
Posterior Stops.....	19
Hook Setting & Adjustments.....	21
Directions for Daily Use.....	26
Operating the Adjustment Key.....	28
Exercise Bite Tab.....	29
Homecare Instructions.....	31
Parts and Tools.....	33
Notes.....	34

Caution: Federal (U.S.) law restricts this device to sale by or on the order of a dentist or physician.

 This device complies with the requirements of directive 93/42/EEC concerning medical devices.

SAVE THESE INSTRUCTIONS

The following words in this manual have special significance:

Warning: Means there is a possibility of injury.

Note: Indicates points of particular interest for more efficient and convenient operation.

Indications

The Thornton Adjustable Positioner[®] 3 (TAP[®] 3) is intended to reduce or alleviate nighttime snoring and obstructive sleep apnea (OSA). The appliance is for adult patients to be used when sleeping at home or in sleep laboratories and is for single-patient use.

Contraindications

This device is contraindicated for patients with loose teeth, loose dental work, dentures, or other oral conditions which would be adversely affected by wearing dental appliances. In addition, the appliance is contraindicated for patients who have central sleep apnea, have severe respiratory disorders, or are under 18 years of age.

The Thornton Adjustable Positioner 3 (TAP[®] 3) is an oral device intended to reduce or alleviate nighttime snoring and obstructive sleep apnea (OSA).

The TAP[®] 3 device consists of an Upper Tray that fits over the upper teeth and a Lower Tray that fits over the lower teeth. A hook mechanism attached to the Upper Tray fits into a Socket attached to the Lower Tray and positions the lower jaw forward, preventing the soft tissue of the throat from collapsing and obstructing the airway. The Adjustment Key of the TAP[®] 3 permits the patient to adjust the protrusion of his/her lower jaw to the most effective and comfortable position.

Linings

The device is fabricated on the dental casts of individual patients. The outer layer of the TAP[®] 3 trays is a durable polymer (polycarbonate) and there is a choice of two unique linings. The first lining, TAP[®] 3 ThermAcryl[®], is a thermoplastic material which softens when heated. Once the outer trays are pressure formed over the dental casts, the ThermAcryl[®] is molded into the trays. At the time of delivery, the trays are placed in hot water, which softens the ThermAcryl[®], and are then fitted to the patient.

Note: ThermAcryl® is a heat sensitive lining and may deform if subjected to temperatures greater than 160°F. If it is heated above 160°F the impressions of your teeth in the tray will deform and your TAP® 3 will no longer fit.

The second lining, TAP® 3 Triple Laminate (TL), consists of a dual laminate polymer plus an outer hard plastic shell. The dual laminate is a sheet of plastic with a layer of soft polyurethane that is bonded to a layer of a hard polymer. In the fabrication process, the dual laminate is pressure formed over the dental casts with the polyurethane side covering the teeth. Then, the hard outer layer is pressure formed over the dual laminate, creating a triple laminated tray. The lining is unique because the trays are returned to the dentist with the patient's dentition already impressed into the tray. Delivering the trays usually does not take as long as the TAP® 3 ThermAcryl® and the lining is much more comfortable in the mouth.

Each TAP® 3 package contains:

1. An Upper and Lower Tray
2. Instructions for Use
3. Storage Case
4. Two Exercise Bite Tabs
5. Adjustment Key

Fig. 6.1 TAP[®] 3

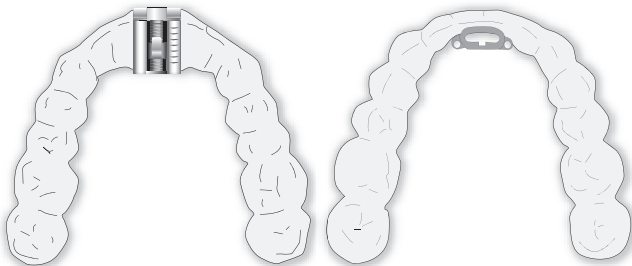

Note: The metal parts are made of medical grade stainless steel. If the patient experiences any reaction, have him/her contact the prescriber immediately.

Note: Read all instructions before using the TAP® 3.

- This device is intended to reduce or alleviate nighttime snoring and obstructive sleep apnea (OSA). If symptoms of breathing difficulties or other respiratory disorders exist or persist, with or without the use of the device, the patient should contact the prescriber immediately.
- The patient may experience soreness or discomfort in the temporomandibular joint (TMJ), jaw, or teeth. If discomfort persists, the patient should contact the prescriber.
- In the morning, some patients may sense a change in their bite. This sensation should disappear within one hour. If it continues for more than four hours, the patient should contact the prescriber.
- The patient may experience obstruction of oral breathing with any oral appliance in the mouth.
- The patient should return to the prescriber at least yearly, or as often as necessary, for re-evaluation. If the TAP® 3 is lined with ThermAcryl®, the lining will need to be replaced at least yearly. If the appliance becomes loose, damaged, or does not fit properly, the patient should contact the prescriber.

Possible Side Effects

There are possible side effects associated with using the TAP® 3 appliance. These side effects are not common. If the patient experiences any of the following side effects, instruct him/her to contact you, the prescriber.

- Slight tooth or gingival discomfort due to pressure of the appliance.
- Excess salivation initially. This will improve as the patient becomes accustomed to wearing the TAP® 3.
- Slight jaw soreness or tightness initially and with adjustments.
- Temporary bite change. This will subside approximately 30 minutes after the TAP® 3 is taken out of the mouth in the morning and the Exercise Bite Tabs are used.
- Unconsciously taking the TAP® 3 out of his/her mouth at night.
- Orthodontic movement of the teeth.
- Pain or dysfunction of the temporomandibular joint and associated muscles.
- Permanent bite change.

Note: The following instructions only pertain to the ThermAcryl[®]-lined TAP[®] 3 trays. For TAP[®] 3 TL instructions, see page 15.

As the patient adapts to the TAP[®] 3, he/she should be able to sleep with it through the night. This typically takes a week.

1. Before you fit the patient with the TAP[®] 3, inspect it to make sure the pieces are not damaged and free from any physical or cosmetic defects. If there is the slightest indication that the device may be damaged or defective, do not fit it. Also, clean the TAP[®] 3 by gently scrubbing it with antibacterial soap and rinsing it thoroughly.

2. Place the lower TAP[®] 3 tray in a water bath that is heated to 160°F until the ThermAcryl[®] lining softens (turns clear). Wet your hands before fitting the tray.

Warning: Do not leave the trays in the water bath too long. The hard plastic shell may warp! The trays should be removed from the water bath and fitted as soon as the lining material turns clear.

3. Position the lower tray over the teeth. Using your thumbs, push the appliance over the teeth starting from the back and working your way forward.

Press down with even pressure, especially in the posterior: do not rock the appliance over the teeth. Some ThermAcryl® will express out of the tray.

4. Remove the lower tray from the mouth by the hard outer shell.

Note: Do not touch the soft lining material. It may distort.

5. While the ThermAcryl® is soft, trim away all material beyond the edge of the hard shell with curved scissors. Use the edge of the tray as a guide. Make certain there is no material on the gingival. Smooth the edge of the tray with a wet finger.

Fig. 10.1 Trimming the lining material

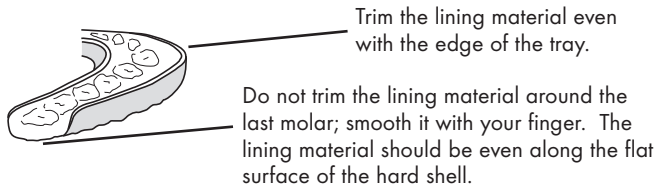

6. Place the lower tray back in the patient's mouth. Let it sit for approximately 1-2 minutes (until the material is almost white).

7. As the material is hardening, take the tray in and out of the patient's mouth several times to ensure that it does not lock on the patient's teeth.

Note: Do not leave in the patient's mouth too long. The material may shrink slightly and "lock" onto the patient's teeth and will be difficult to remove.

8. Repeat the same process for the upper tray.

Note: If more material extrudes onto the soft tissue, trim as before, reheat and then refit. When all trimming is completed, smooth the edge of the tray with a wet finger.

9. Once both trays are properly fitted and trimmed, allow them to bench cure or place them in a cup of cool water for a few minutes until the ThermAcryl[®]-lining hardens (turns white).

10. Have the patient place both trays in his/her mouth (they should "snap" over the teeth, but not uncomfortably). Instruct the patient to hook the trays together outside of the mouth before putting the appliance in the mouth.

11. Ask the patient if:

- a. the units are tight, but not uncomfortable
- b. equal fit in all areas
- c. comfortable to the tongue
- d. he/she is able to remove the units

If the patient answers "no" to any of the above questions, reheat, refit, cool and seat the TAP® 3 appliance in the mouth until it is comfortable for the patient.

12. With both trays in his/her mouth and hooked together, adjust the patient's jaw to a normal bite position (lips together, teeth apart and lower jaw not pulled forward) by dialing the Adjustment Key.

Note: This does not have to be exact, it is just a position that is easy to find as a starting point.

13. With the patient in this position, look at the lower unit in relation to the upper unit in the anterior area. It is extremely important that there is a minimum of 1 mm space bilaterally in the posterior areas at all times, in all positions.

If the practitioner desires posterior support, which AMI recommends, he/she can add it once the patient reaches the final treatment position.

Warning: If the trays disengage, instruct the patient not to reengage the trays while still in the mouth because if he/she bites down on the Hook he/she could damage it or the Socket or pinch his/her tongue. If any damage occurs, tell the patient not to use the appliance and return to your office for repair.

Note: The ThermAcryl[®]-lining will have to be relined within 12 months. If the appliance needs to be relined before this time, ask the patient how he/she is caring for the appliance. See Homecare Instructions on page 31.

Reline Instructions

1. Heat the trays in a hot water bath (approx. 160°F) until the ThermAcryl® turns clear. Do not leave the trays in the water bath too long. The trays will warp.
2. Remove the ThermAcryl® with a spatula. Let trays cool.
3. Place the ThermAcryl® beads in a hot water bath and heat until the beads coagulate and become clear. (You can buy the ThermAcryl® from your laboratory.)
4. Fill the trays completely to the top with the heated ThermAcryl®.
5. Refit the trays to patient. See steps 3-13 on pages 9-12.

Note: The following instructions pertain to the TAP[®] 3 Triple Laminate (TAP[®] 3 TL) trays. For the TAP[®] 3 ThermAcryl[®] instructions, see page 9.

The lining of the TAP[®] 3 TL is a significantly different material than the ThermAcryl[®]-lined TAP[®] 3. It is essential to make certain that both trays fit over the patient's teeth.

Note: If the trays are too loose or too tight, call the laboratory that made the device to discuss the case.

1. Before you fit the patient with the TAP[®] 3 TL, inspect it to make sure that the pieces are not damaged and free from physical or cosmetic defects. If there is the slightest indication that the device may be damaged or defective, do not fit it. Also, clean the TAP[®] 3 by gently scrubbing it with antibacterial soap and rinsing it thoroughly.
2. Start with the lower tray. Position it over the teeth. Using your thumbs, push the appliance on the teeth starting from the back and working your way forward.
3. If trays are too tight, see Tray Adjustments on page 17.

4. Repeat the same process with the upper tray.
5. Have the patient place both trays in his/her mouth (they should "snap" over the teeth, but not uncomfortably). Instruct the patient to hook the trays together outside of the mouth before putting the appliance in the mouth.

Ask the patient if:

- a. the units are tight, but not uncomfortable
- b. equal fit in all areas
- c. comfortable to the tongue
- d. he/she is able to remove the units

If the patient answers "no" to any of the above questions, slightly adjust the TAP® 3 TL appliance until it is comfortable for the patient. See Tray Adjustments on page 17.

6. With both trays in his/her mouth, and hooked together adjust the patient's jaw to a normal bite position (lips together, teeth apart and lower jaw not pulled forward) by dialing the Adjustment Key.

Note: This position does not have to be exact, it is just a position that is easy to find as a starting point.

7. With the patient in this position, look at the lower unit in relation to the upper unit in the anterior area. It is extremely important that there is a minimum of 1 mm space bilaterally in the posterior areas at all times, in all positions. This will allow you to add posterior stops once the patient has found a treatment position. If the practitioner desires posterior support, which AMI recommends, he/she can add it once the patient reaches the final treatment position.

Warning: If the trays disengage, instruct the patient not to reengage the trays while still in the mouth because if he/she bites down on the Hook he/she could damage it or the Socket or pinch his/her tongue. If any damage occurs, tell the patient not to use the appliance and return to your office for repair.

Tray Adjustments

Adjustments can be made to the TAP® 3 TL trays and/or the lining if they are too tight. If adjustments need to be made, it is suggested that you contact the laboratory that made the TAP® 3 TL to discuss the case.

Do not remove too much of the TL lining at once. This may cause the tray to lose retention and will ruin the trays because the TL lining cannot be added back to the trays. If the trays are over-adjusted the laboratory may charge you for a re-make of the trays. **Be conservative with your adjustments.**

If the trays are too loose, return them to the laboratory. If the trays are too tight follow the instructions below.

1. First reduce the height of the flanges covering the teeth. Do not relieve the lining.
2. If the patient still complains of tightness or discomfort of the anterior teeth, carefully remove a small amount of the dual laminate lining from the areas of the tray with too much retention. Use a thin straight acrylic burr and then a sharp knife to remove the tags. See the burr suggestions below.
3. Fit the tray in the patient's mouth with each adjustment.

Burr Suggestions

The TAP[®] 3 TL can be modified with straight burrs from Brassler USA Soft Reline Removal & Trimming Kit. Toll-free: 1-800-841-4522.

It is suggested that you order only three burrs out of the kit.

Those include numbers:

261GSQ-023- small; 251GSQ-060 - medium; 79GSQ-070 - large

Or you can call your laboratory or Airway Management, Inc. to purchase a TAP[®] Burr Kit. If your laboratory does not carry the TAP[®] Burr Kit, call Airway Management, Inc.

It is extremely important that there is a space bilaterally between the trays prior to adding the acrylic posterior stops. The objective is to create bilateral, even posterior stops at the patient's treatment position. Since the relationship of the maxilla to the mandible changes with the changes in protrusion, this procedure must be repeated if the treatment position changes.

To add Posterior Stops:

1. Roughen the hard plastic in the area of the 1st and 2nd molar.
2. Lubricate the upper tray with Vaseline and place in the patient's mouth. The Vaseline will keep the trays from sticking together when adding the Posterior Stops.
3. Place the lower tray in the patient's mouth while the acrylic is in the doughly stage.
4. Help the patient to couple the upper TAP[®] 3 tray with the lower while the lower is in the patient's mouth. Have the patient gently snap the upper tray over his/her teeth by pushing it up with his/ her thumbs. Be sure the patient doesn't bite down on the stops. The Hook should be set **in the patient's treatment position**. See Hook Setting and Adjustments on page 21.

5. With the trays coupled in the mouth, have the patient bite down.
6. Once the Stops are set, first smooth the area with your finger. This will ensure there isn't any rough spot that may irritate the patient.

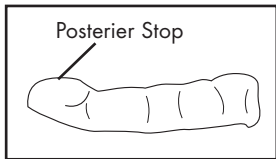

Fig. 20.1 Side view of lower tray with Posterior Stop

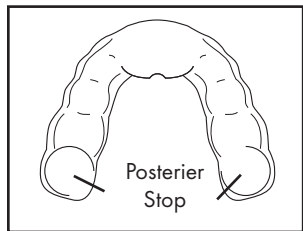

Fig. 20.2 Top view of lower tray with Posterior Stops

Note: The setting adjustments are written from the perspective of the practitioner looking at the patient.

The initial treatment position of the Hook should be set by the prescriber according to the following instruction. The Hook moves forward and back by using the Adjustment Key to dial the Adjustment Screw clockwise or counter clockwise. Each 180° turn is a .25mm adjustment.

1. Have the patient place the device in his/her mouth. Instruct the patient to couple the trays together before putting in the device.
2. Dial the Adjustment Key clockwise to the patient's **maximum mechanical protrusion (MMP)**. The patient will feel a slight stretch in his/her temporalmandibular joints at this point. If the patient doesn't reach this maximum passive protrusion with the hook located in the slot of the lower socket then have the patient place the hook behind the socket and continue to dial the adjustment key until he/she reaches this point. See figure 23.1 on page 23.

3. Remove the trays by pulling on the posterior of the trays.
4. Mark the Base Plate even with the anterior side of the hook (see figure 25.1 on page 25) to indicate the MMP point. Use a cut-off disc or a diamond burr to mark the Base Plate. The MMP mark is a permanent record of the patient's maximum range of motion at the initiation of treatment.
5. Place the device back in the patient's mouth.
6. Dial the Hook counter clockwise until the patient's teeth are end to end. This is the patient's **starting position**.
7. Again, mark the Base Plate even with the anterior side of the Hook. This indicates the patient's starting position.

Note: On the protrusion gauge on the Base Plate, each mark and each space between the marks are 1 mm wide. The protrusion gauge is 7 mm long from the front of the plate to the most posterior mark. (See figure 25.1 on page 25.) Have the patient wear the appliance in this end-to-end position for 3 - 4 nights before starting adjustments.

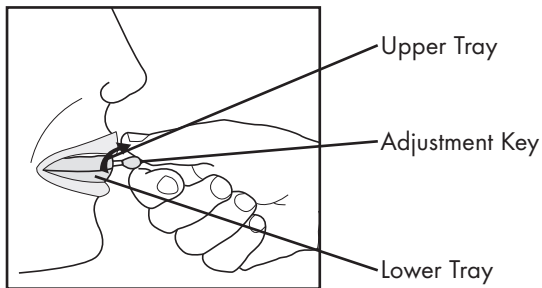

Fig. 23.1

8. From the starting position instruct the patient to turn the Adjustment Key a half turn (180 degrees) counter-clockwise per night until all the symptoms are alleviated. The patient should leave the hook in the adjusted position and not dialed back to remove the appliance. The appliance should be detached from the teeth before unhooking.

9. If any position becomes uncomfortable, the patient should dial the Hook back until pain subsides. Instruct the patient not to start dialing forward again until the jaw is comfortable. If the patient's pain does not subside, you may want to schedule a consultation for evaluation.

Note: If the patient's mandible needs to be moved further forward you can instruct the patient to engage the hook behind the socket.
(See figure 25.2)

Note:

Have the patient return to your office for examination and assessment to ensure the TAP® 3 is not damaged and is still effectively treating the patient's sleep disordered breathing. If the patient loses count of how far forward the Hook is dialed, have him/her dial the Adjustment Key clockwise (or back) until the teeth are end to end (or in the starting position). Then have the patient dial the Hook as many turns counter clockwise (or forward) as the previous night's Hook position.

Fig. 25.1

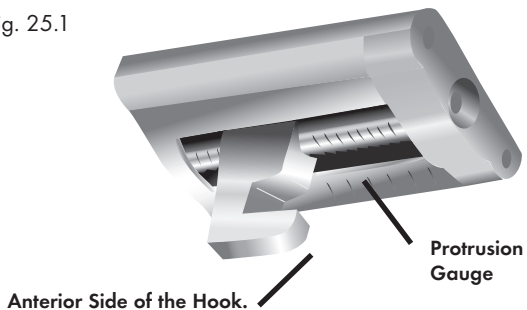
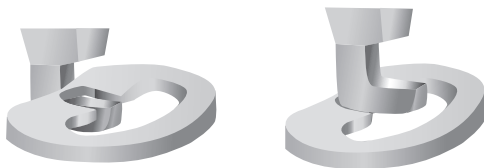

Fig. 25.2 Two positioning options for the Hook and Socket.



Directions for Daily Use

Instruct your patient in the daily use of the TAP® 3 appliance. Also give your patient a copy of the Patient Instruction Booklet.

1. The patient should brush his/her teeth and floss well before inserting the TAP® 3.
2. Instruct the patient to inspect the device prior to each use. If there is any material separation, material degradation or cracks the patient should discontinue use and contact you, the prescriber.
3. Tell the patient to engage the Hook of the upper tray with the Socket in the lower tray before placing the trays in his/her mouth. The patient should make sure the Hook is not dialed too far forward that he/she can not comfortably snap the trays over his/her teeth while engaged. The patient should use his/her thumbs to push the tray from the bottom to snap it over the upper teeth. Repeat the same process for the lower tray

Note: It is difficult for the patient to engage the Hook and Socket if the trays are already in their mouth because the Hook receptical in the Socket is small and may pinch the tongue.

4. The patient should gently relax once the TAP® 3 is in his/her mouth.

5. After use, the patient can remove either the upper or lower tray by gently opening the mouth while the Hook is still engaged. At the same time, the patient can lift up on the lower tray or pull down on the upper tray to loosen either tray and remove.

Warning: Instruct the patient that if the trays disengage while in the mouth, he/she should take the trays out, reengage the Hook and Socket and place back in his/her mouth. If the patient tries to reengage the trays while still in the mouth and the patient bites down on the Hook, it might damage the Hook or Socket.

Warning: The TAP® 3 trays should never be worn separately. The patient should always wear both trays when using the appliance.

Operating the Adjustment Key

Note: Operating the Adjustment Key is written from the perspective of the patient with the appliance in his/her mouth.

1. To pull the lower jaw forward with the appliance in the mouth, instruct the patient to turn the Adjustment Key counter clockwise (towards the left ear). See figure 28.1.
2. To return the lower jaw to the starting position with the appliance in the mouth, have the patient turn the Adjustment Key clockwise (toward the right ear).

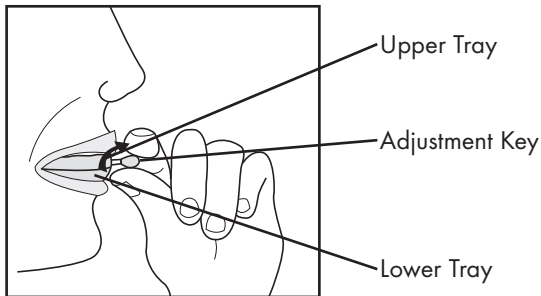

Fig. 28.1 Patient advancing the lower jaw forward.

When the lower jaw is pulled forward during the night, it may make the jaw muscles sore and temporarily change the bite. The Exercise Bite Tabs are intended for the patient to use as an exercise tool to put the jaw back into normal bite position.

1. Take both Exercise Bite Tabs provided with the patient's case.
2. Place one Exercise Bite Tab between the teeth on each side of the patient's mouth. See figure 30.1 on page 30.
3. Instruct the patient to pull his/her lower jaw back.
4. Once the patient's jaw is in the back position, have the patient squeeze as if to put the back teeth together. See figure 30.2 on page 30.
5. Remove the Exercise Bite Tabs to see if the teeth come together.
6. Repeat the process until the jaw is back in normal bite position.

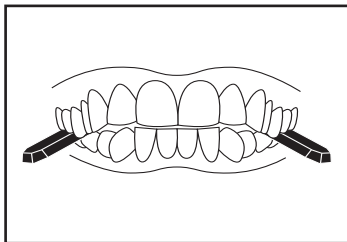

Fig. 30.1 Exercise Bite Tabs positioned between teeth.

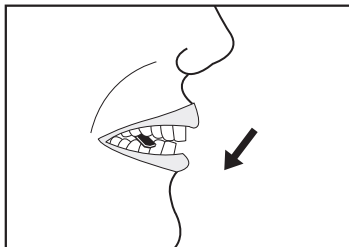

Fig. 30.2 Squeeze the back teeth together.

Warning: Instruct the patient that it is imperative to use the Exercise Bite Tabs each morning to reduce the risk of permanent bite change.

Each morning after use, instruct the patient to thoroughly clean the TAP[®] 3 appliance using a regular soft toothbrush, cool water and an antibacterial liquid soap. Hot water should not be used.

Instruct the patient to dry the appliance completely before storing in the container. It may help to leave the container open to ensure that the TAP[®] 3 dries thoroughly.

The patient may disinfect the TAP[®] 3 appliance every two weeks in a solution of mouthwash and water (half mouthwash and half water), or the patient can substitute a denture cleanser, like Efferdent, for mouthwash. The TAP[®] 3 should be soaked in this solution for only 10-15 minutes and rinsed thoroughly with water before use or storage. Instruct the patient to brush his/her teeth and floss well before inserting the TAP[®] 3 in the mouth.

Note: Using mouthwash or a denture cleanser will cause the plastic materials of the appliance to deteriorate more rapidly. The best way to keep the TAP[®] 3 clean is to brush it each morning after use. The patient should sparingly soak the appliance if further measures need to be used in order to clean the appliance.

Warning: The TAP[®] 3 should be stored in a cool, dry place. The appliance is made from sensitive materials and should not be stored where temperatures exceed 120°F, such as in the glove compartment of a car or the cargo hold of an airplane. In addition, explain to the patient not to clean the appliance in hot or boiling water, nor to soak it in bleach or hydrogen peroxide which will cause the trays to distort or the lining to become brittle and delaminate.

Warning: Instruct the patient not to disassemble any of the TAP[®] 3 hardware. The TAP[®] 3 is a medical device and the patient must not tamper with it other than following the specific instructions in this booklet.

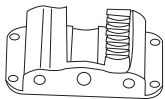

Base Plate



Socket



Hook



Front Plate

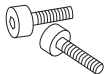

Locking Screws



Adjustment Screw



TAP[®] 3
Adjustment Key

We are proud to offer our customers the TAP® 3.

The Thornton Adjustable Positioner® 3 (TAP® 3)

is manufactured by:

Airway Management, Inc.

Post Office Box 12557

Dallas, Texas 75225-0557

866.AMI.SNOR www.tapintosleep.com

© Airway Management, Inc.