

Studies have indicated that the following normal variations can be expected for the four parameters described:

Normal Jaw Movement Parameters in mm

Measurement	Males	Females
Maximum Interincisal Opening	44-77	42-75
Maximum Protrusion	4-14	5-13
Maximum Left Laterotrusion	6-16	5-15
Maximum Right Laterotrusion	5-13	5-13

The TriMeasure is fully autoclavable



Your Full Service Dental Laboratory

423 South 13th St.
Terre Haute, IN 47807
Toll Free: 800/457-0504
Local: 812/232-6026
Fax: 812/234-4464
Website: www.johnsdental.com

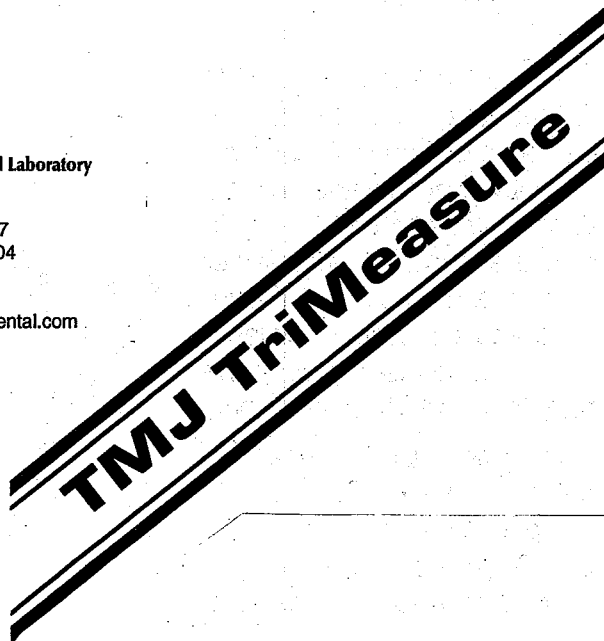

TMJ TriMeasure

The TMJ TriMeasure is designed to help the clinician obtain an objective measure of jaw function that is reliable, repeatable, inexpensive and time saving.

Four measurements are required:

- 1) Maximum interincisal opening
- 2) Maximum protrusion
- 3) Maximum left laterotrusion
- 4) Maximum right laterotrusion

The description of how to use the TMJ TriMeasure for each of the above measures will be described separately.

1) Maximum interincisal opening:

Maximum interincisal opening is measured between the incisal edges of the first maxillary and mandibular incisors after the subject is instructed to open the mouth as wide as possible. The amount of overbite (vertical overlap of maxillary over mandibular teeth) should be added to the interincisal measurement (Fig. 1).

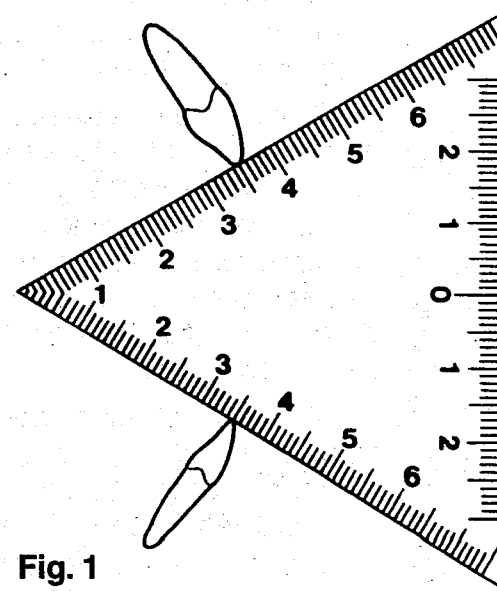

Fig. 1

Hold the TMJ TriMeasure between thumb and forefinger so that the apex of the triangle, with equally marked sides, points into the mouth. Instruct the subject to open his mouth as wide as possible, and slide the TMJ TriMeasure between the

incisors. Look at the markings at the incisal edges and, by tipping the TMJ TriMeasure, obtain equal measures on both sides. This measurement added to the overjet is maximum interincisal opening.

Once the subject has opened his mouth as wide as possible, the thumb and third fingers are placed on the incisal edges of the maxillary and mandibular teeth, respectively. Gentle pressure is applied to open the mouth wider. In this way both the passive range of joint motion and the "end feel" to this movement are noted. Excessive force should be avoided so as not to damage the temporomandibular joint.

2) Maximum protrusion:

Maximum protrusion is obtained by first measuring the amount of overjet (horizontal overlap of maxillary over mandibular teeth) and then instructing the subject to protrude his lower jaw as far as possible. The distance from the facial surface of the maxillary first incisor to the incisal tip of the mandibular first incisor is measured and added to the overjet to give the maximum protrusion (Fig. 2a and 2b).

With the teeth in occlusion, hold the TMJ TriMeasure so that the apex of the triangle is against the facial surface of the mandibular incisor chosen as a reference. Measure the distance to the facial surface of the maxillary incisor.

Instruct the subject to protrude the mandible as far as possible. Repeat the measurement with the apex of the triangle on the facial surface of the maxillary incisor, and record the distance to the facial surface of the mandibular incisor. The

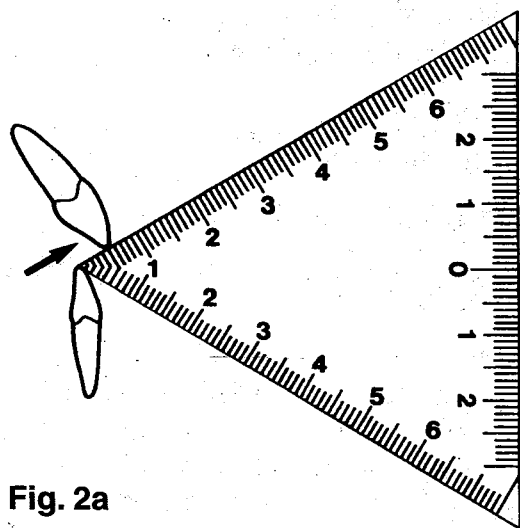

Fig. 2a

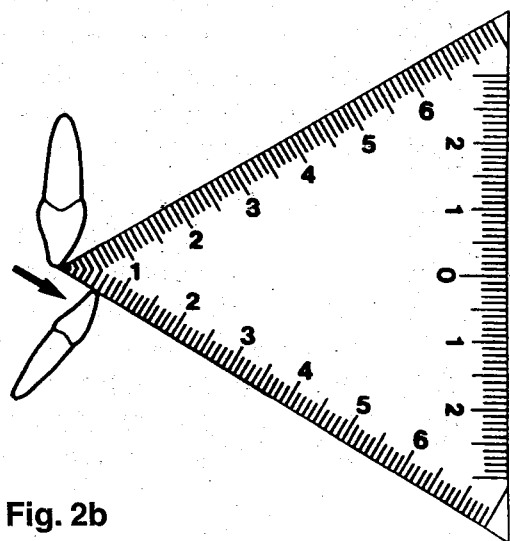

Fig. 2b

sum of these two measurements is maximum protrusion.

3) Maximum laterotrusion:

Maximum left and right laterotrusion are assessed by finding an anatomical landmark such as the midlines of the maxillary and mandibular incisors, so that measurements can be easily repeated from a consistent point of reference.

The subject is instructed to slide the jaw laterally as far as possible while *keeping the teeth in contact*.

Measurement between these landmarks will give maximum laterotrusion. Should there be a midline discrepancy, a mark can be made on the mandibular incisor to coincide with the maxillary midline and then be used as the landmark (Fig. 3a and 3b). With the teeth in occlusion, check the midline differences of the maxillary and mandibular incisors.

Using the base of the TMJ TriMeasure, align the central darkened marking with the midline between the central maxillary incisors. Instruct the subject to slide the mandible either left or right as far as possible. Measure the distance moved by the landmark that corresponded to the maxillary midline in occlusion.

To standardize the measurements and insure that accurate comparisons can be made from one recording to the next, the same landmarks should be used.

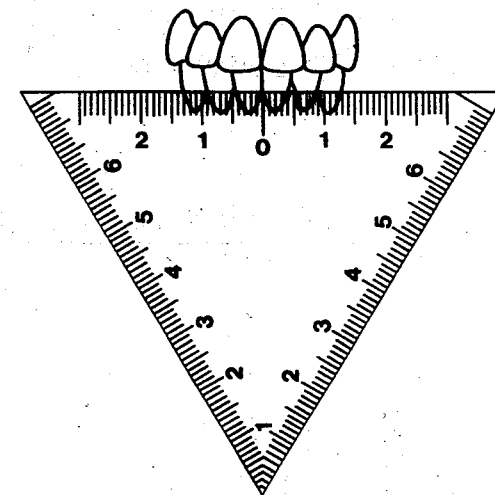

Fig. 3a

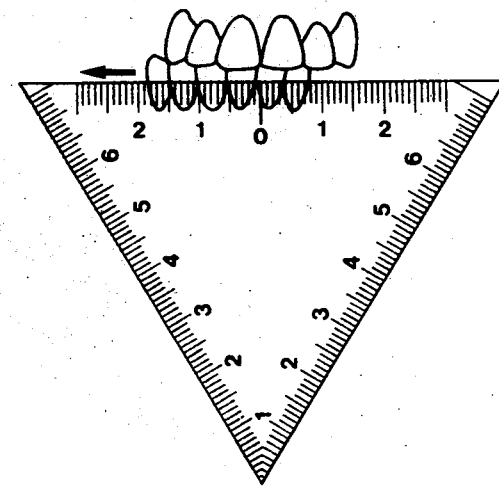

Fig. 3b